

W. GMINDER.

Improvement in Heddle Actuating Mechanism.

No. 132,279.

Patented Oct. 15, 1872.

— FIG. 1. —

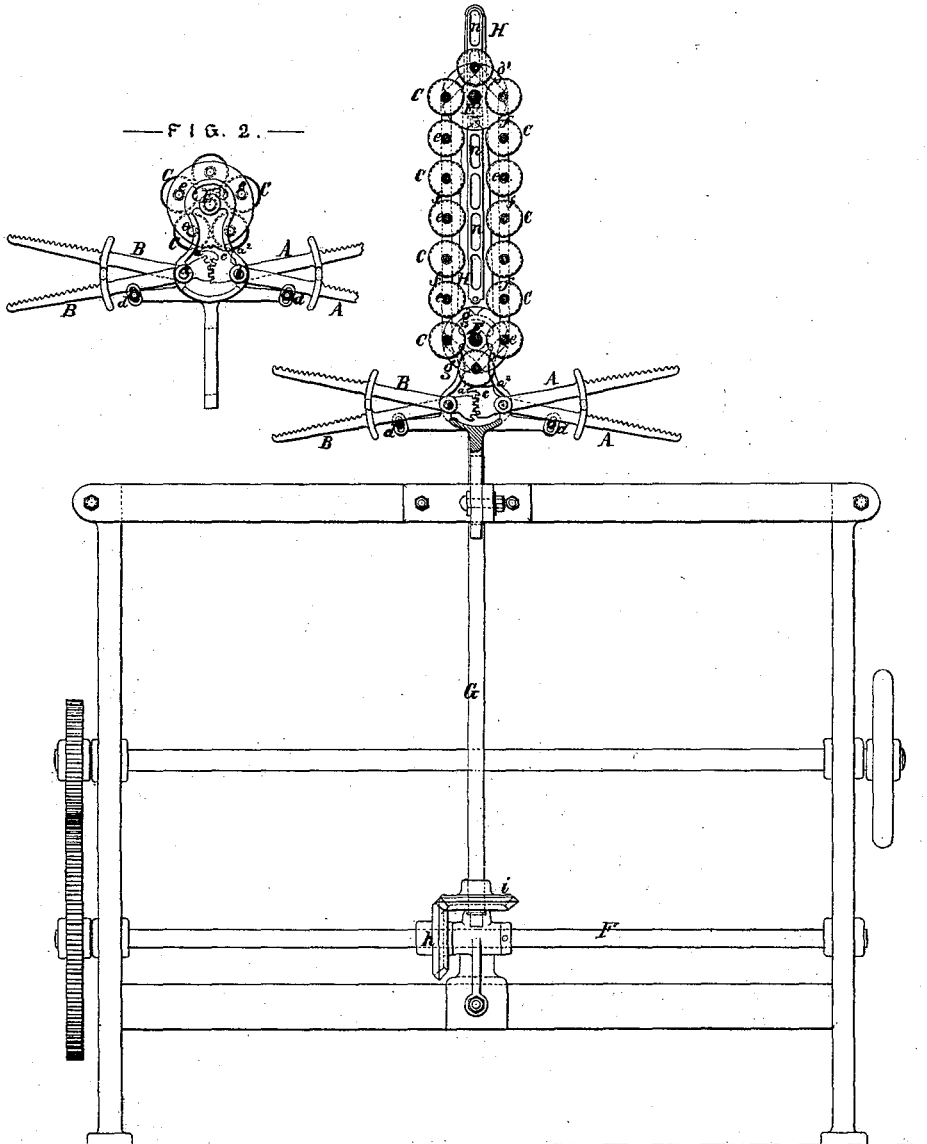

Witnesses:

*H. H. Mappin*  
*H. G. Stewart*

Signed:

*William Gminder*  
*by Chas. Bergman, his Attorney*

W. GMINDER.

Improvement in Heddle Actuating Mechanism.

No. 132,279.

Patented Oct. 15, 1872.

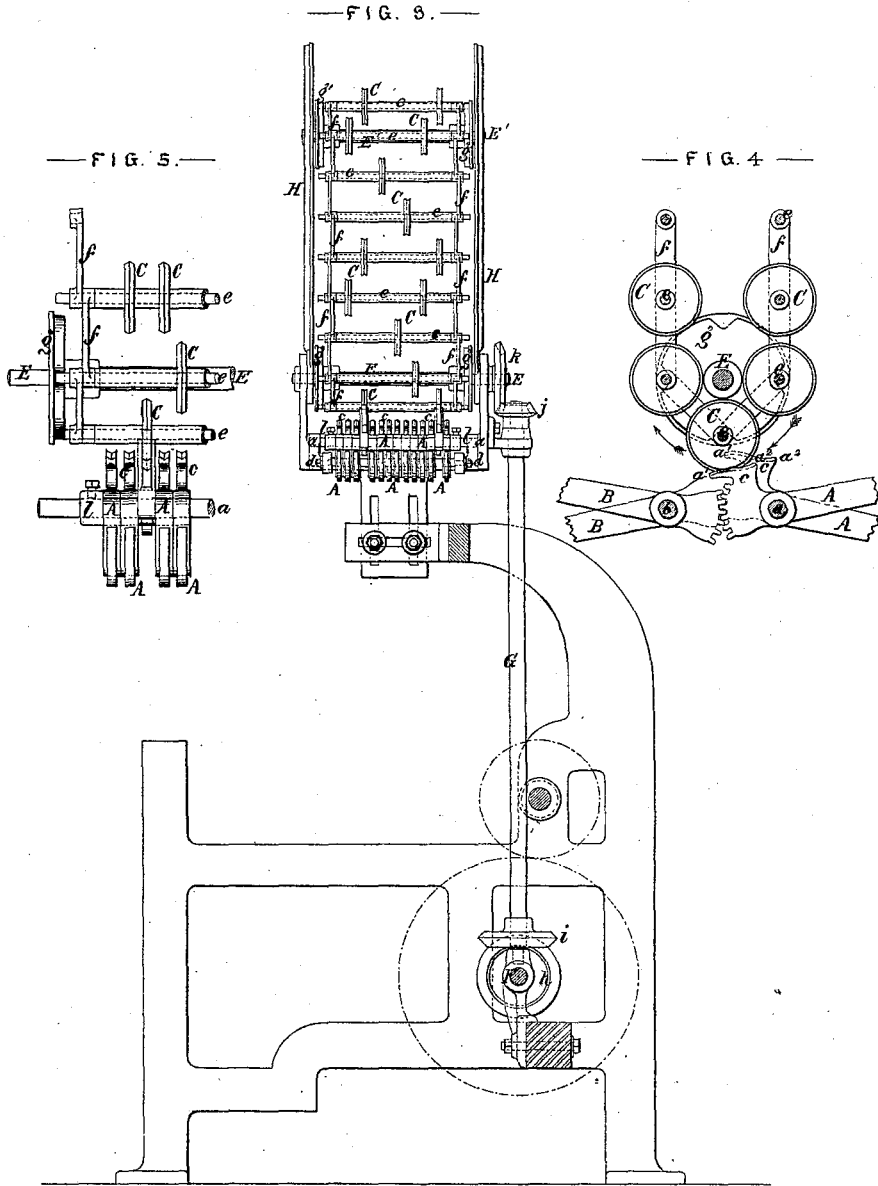

Witnesses:

*A. A. Maguire*  
*H. G. Stewart*

Signed:

*William Gminder*  
 by *Theod. Bergner*  
*his Attorney*

# UNITED STATES PATENT OFFICE.

WILLIAM GMINDER, OF REUTLINGEN, GERMANY.

## IMPROVEMENT IN HEDDLE-ACTUATING MECHANISMS.

Specification forming part of Letters Patent No. 132,279, dated October 15, 1872.

*To all whom it may concern:*

Be it known that I, WILLIAM GMINDER, of Reutlingen, in the Kingdom of Württemberg, Germany, have invented a certain Improvement in Looms, of which the following is a specification:

My invention relates mainly to that class of power-loom wherein figured goods are woven with the aid of a harness of numerous heddles and a complex treading motion, arranged to carry the variety and complication of designs to the extent possible without a Jacquard appendage; the object of this invention being to provide a more simplified and efficacious mechanism for actuating any admissible number of treadles with great certainty and variety of changes, and without injurious shock or vibration from this mechanism in actuating the harness at the highest rate of speed compliant with the proper functions of other parts of the machine.

This improved mechanism, which I have termed a "Revolver Treading Motion," is so constructed that all movements of the treadles are derived from parts which are kept in continuous rotative motion, and which produce a slowly-commencing but very precise movement of the harness without injurious jar or vibration. A feature of great practical importance in my improved treading motion consists in avoiding the alternate release and throwing into action of hooks or of any other intermittently-connected parts, thus combining with its advantages for speed an extensive variation of designs, great simplicity of the mechanism producing the most complex patterns. This improved revolver treading motion is so far complete within itself, and so little dependent upon the general construction of the loom in all other respects, that it can be readily attached to any loom already built or in operation. A light frame-work, carrying the treading motion and absorbing within itself all its working strains, is attached to the front side of the arched frame that ordinarily supports the rolls on which the harness hangs, motion being given to the improved treading mechanism through a light vertical shaft driven from the lathe shaft of the loom.

On reference to the annexed drawing making part of this specification, Figure 1 is a front elevation of my improved treading mo-

tion in position upon the frame of a loom; Fig. 2 is an elevation of a simplified construction of my improvement, adapted to the production of simple intertextures; Fig. 3 is a side elevation of the improved treading mechanism in position upon the frame of a loom; and Figs. 4 and 5 are detached views of details.

A A A and B B B are the treadles, arranged in pairs, each pair geared together in the manner clearly shown in Figs. 1 and 2, and all vibrating upon fulcrum-pins *a* and *b*, respectively. To the outer ends of the long arms of treadles A A B B, the heddles are hung, being held in their normal lower position by tension springs in the usual well-understood manner, not illustrated in the drawing. The downward movement of the treadle is limited by rods *d d*, on which their outer arms bear while in a state of rest. Treadles A A A have each on their inner shorter arms a projection, *c*, with a curved upper face, *a' a'*, (Figs. 1 and 2.) A series of rollers, C C C, moving downward and around a shaft, E, in continuous rotation, are here brought in rolling contact with the projections *c c*, and in bearing upon their curved faces *a' a'* they depress the short arms of A and B, thus elevating their long outer arms and with them the corresponding portion of the harness. The pattern-chain, bringing the whole series of rollers C C C into consecutive action in the order required for a given pattern, consists of a number of light cylindrical rods, *e e e*, connected at both ends by links *f f f*, in the manner of an endless chain, which is carried over suitably-notched disks *g g'* on shafts E and E'. Continuous revolving motion is imparted to the shaft E from the lathe-shaft F of the loom by means of bevel-wheels *h i* at the lower end of a vertical shaft, G, and through a second pair of wheels, *j k*, Fig. 3, at its upper end. The diameters of these wheels are relatively so proportioned that for every stroke of the lathe of the loom the pattern-chain will advance the length of one link, and thus invariably bring one set of rollers, C C, and their corresponding treadles into action during this interval of time. The treadles are placed side by side in any required number of pairs upon their fulcrum-rods *a* and *b*, and the entire set are then confined endwise upon these rods between adjustable collars *l l*; and in the order in which the pattern requires each pair

of the treadles to be raised, its corresponding roller C is provided and repeated, as the case may be, in the pattern-chain; thus some of the rods *ee* of the chain may carry only one, and others two or more rollers. Now, each of these rollers being laterally confined to its prescribed position in the line of motion of the chain, and its face being no wider than the face *a<sup>1</sup> a<sup>2</sup>* of its corresponding treadle, they cannot fail to operate reliably at any speed practical with other working conditions. This certainty of action of the revolver treading motion is still further improved by grooving the faces *a<sup>1</sup> a<sup>2</sup>* lengthwise, and by conforming the face of the rollers C·C thereto, as shown in Figs. 4 and 5, thus guiding each other and preventing all lateral vibration of the levers. The extension frames H H supporting the pattern-chain are each provided with a series of oblong spaces, *nn*, Fig. 1, so divided relatively to the length of links *ff* that the pattern-chain may be lengthened or shortened and the design complicated or simplified to any extent within the end limits of frames H H, the several openings *nn* admitting the required changes in the position of bearings of the upper shaft E' carrying the chain over disks *g' g'*. It will be observed that this improved mechanism combines with marked simplicity and reliability of action the advantages of completeness within itself, and of such working position relatively to the other parts of any loom of the usual varieties of construction that it can be easily adapted to many existing patterns, and thus serve to improve machines already in actual but more limited operation. All strains due to the action of the improved revolver treading motion being resisted and absorbed within its own frame-work, its operation causes no injurious vibrations in the other parts of the loom, and requires very little stability and bracing in its support.

The modification represented in Fig. 2 of the drawing will now be easily understood. The extension pieces H H and pattern-chain are here entirely removed, and a plain shaft, E<sup>3</sup>, carrying a limited set of rollers, C C, takes their place. This shaft receives a continuous revolving motion, and its sets of rollers C C are consecutively brought into action precisely as

hereinbefore described. The greatest number of changes attainable by this simplified construction of the improved treading motion corresponds with the number of axles *eee*, of which Fig. 2 represents five. It will be evident that, to insure smooth and easy working of the described improved mechanism, and to avoid undue frictional strain and resistance, proper skill and care must be used in the construction of the curved face of projections *c* on the treadles, which should be so shaped as to commence moving gradually, with the least possible concussion, and also to cause a brief dwell in the elevated position of the heddle attached to the outer arms.

It may here be proper to remark that the results in practice have amply sustained the objects of my improvement, and that its simplicity and the avoidance of dead centers or states of rest in its operation, enable it to run at a high speed heretofore inadmissible in connection with treadle motions for complex patterns.

I have been particular in describing a certain means of imparting motion to the improved treading mechanism from the lathe-shaft, the said mode of driving being direct and easily available, and therefore generally adopted in practice; but it must be evident that the required continuous rotary motion may be carried to the improved treadle motion from other parts of the loom machinery, thus serving the same end without impairing the object and practical efficiency of my improvement.

I claim as my invention—

1. The combination of the treadles A B, projection *c*, rollers C C, links *ff*, disks *g g'*, shafts E E', and frames H H, all arranged to operate as and for the purpose hereinbefore described.

2. The combination of the geared treadles A B, projection *c*, and continuously-rotating pattern-chain, having rollers C C, all arranged to operate in the manner and for the purpose above set forth.

WM. GMINDER.

Witnesses:

GILES KRIMMEL,  
GEORGE HAMMER.